

Authentic

STANDARDS IN FORCE

Metal substrate and coating
as per Standard EN 10346

Organic coating
as per standards EN 10169
and (F) XP P 34.301

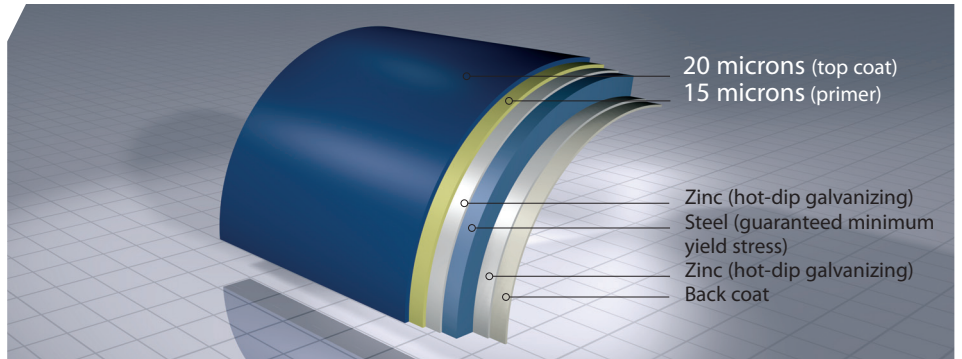

TYPE OF COATING	Thermosetting high durability polyester resin : - Very good resistance to corrosion - Good colour and appearance stability - Good external sustainability - Good metal forming suitability	
COATING CLASS	Interior environment : class IIIa (XP P34.301) – category CPI4 (NF EN 10169) Exterior atmosphere : class VI (XP P 34.301) – category RUV4 and RC4 (NF EN 10169)	
SECTOR OF APPLICATION	Roofing and cladding for : - Industrial or normal urban environments - Marine environments : HAIRULTRA on the back face recommended	Special colours for roof and wall application as patinated zinc, copper aspect ...
DESCRIPTION OF ORGANIC COATING		
	COMPOSITION	Front : 15 microns of primer - 20 microns of top coat Back : Class II or category CPI2 back coat
	POSSIBILITIES	Both sides : 35 microns on request
	GLOSS	15 GU, Semi matt

COATING PROPERTIES

<p>▶ PAINT HARDNESS</p> <table border="1"> <tr> <td>Pencil hardness</td> <td>F-H</td> </tr> </table>	Pencil hardness	F-H	<p>▶ THERMAL RESISTANCE</p> <table border="1"> <tr> <td>Oven</td> <td>Maxi : 90 °C</td> </tr> </table>	Oven	Maxi : 90 °C	<p>▶ CHEMICAL AGENTS</p> <table border="1"> <tr> <td>Acids, bases and solvents</td> <td></td> </tr> <tr> <td>Acids and bases</td> <td>good</td> </tr> <tr> <td>Mineral oils</td> <td>very good</td> </tr> <tr> <td>Aliphatic solvents</td> <td>very good</td> </tr> <tr> <td>Aromatic solvents</td> <td>good</td> </tr> <tr> <td>Ketonic solvents</td> <td>poor</td> </tr> <tr> <td>Chlorine solvents</td> <td>poor</td> </tr> </table>	Acids, bases and solvents		Acids and bases	good	Mineral oils	very good	Aliphatic solvents	very good	Aromatic solvents	good	Ketonic solvents	poor	Chlorine solvents	poor
Pencil hardness	F-H																			
Oven	Maxi : 90 °C																			
Acids, bases and solvents																				
Acids and bases	good																			
Mineral oils	very good																			
Aliphatic solvents	very good																			
Aromatic solvents	good																			
Ketonic solvents	poor																			
Chlorine solvents	poor																			
<p>▶ ABRASION RESISTANCE</p> <table border="1"> <tr> <td>Sand blasting</td> <td>40 liters</td> </tr> </table> <table border="1"> <tr> <td>Taber</td> <td>60 mg</td> </tr> </table>	Sand blasting	40 liters	Taber	60 mg	<p>▶ COLOUR AND GLOSS</p> <table border="1"> <tr> <td>Resistance to UV (lab. test)</td> <td>Delta E ≤ 2 Gloss retention ≥ 80%</td> </tr> </table>	Resistance to UV (lab. test)	Delta E ≤ 2 Gloss retention ≥ 80%	<p>▶ FIRE BEHAVIOR</p> <table border="1"> <tr> <td>Reaction to fire</td> <td></td> </tr> <tr> <td>M0 (M classification)</td> <td></td> </tr> <tr> <td>A1 (Euroclass simple skin)</td> <td></td> </tr> <tr> <td>F (Euroclass double skin)</td> <td></td> </tr> <tr> <td>(see also our fire guide)</td> <td></td> </tr> </table>	Reaction to fire		M0 (M classification)		A1 (Euroclass simple skin)		F (Euroclass double skin)		(see also our fire guide)			
Sand blasting	40 liters																			
Taber	60 mg																			
Resistance to UV (lab. test)	Delta E ≤ 2 Gloss retention ≥ 80%																			
Reaction to fire																				
M0 (M classification)																				
A1 (Euroclass simple skin)																				
F (Euroclass double skin)																				
(see also our fire guide)																				
<p>▶ FLEXIBILITY</p> <table border="1"> <tr> <td>Brutal distortion</td> <td>No peeling</td> </tr> </table> <table border="1"> <tr> <td>Bending</td> <td>T = Radius/Thickness 2T no cracking</td> </tr> </table> <table border="1"> <tr> <td>Ericksen</td> <td>Very good</td> </tr> </table>	Brutal distortion	No peeling	Bending	T = Radius/Thickness 2T no cracking	Ericksen	Very good	<p>▶ CORROSION</p> <table border="1"> <tr> <td>Salt spray</td> <td>500 hours</td> </tr> </table> <table border="1"> <tr> <td>Humidity resistance</td> <td>1.500 hours</td> </tr> </table>	Salt spray	500 hours	Humidity resistance	1.500 hours									
Brutal distortion	No peeling																			
Bending	T = Radius/Thickness 2T no cracking																			
Ericksen	Very good																			
Salt spray	500 hours																			
Humidity resistance	1.500 hours																			